

No. 610,319.

Patented Sept. 6, 1898.

J. W. BROWN, JR.  
DOUBLE TURRET LATHE.

(Application filed June 23, 1893.)

(No Model.)

4 Sheets—Sheet 1.

FIG. 1.

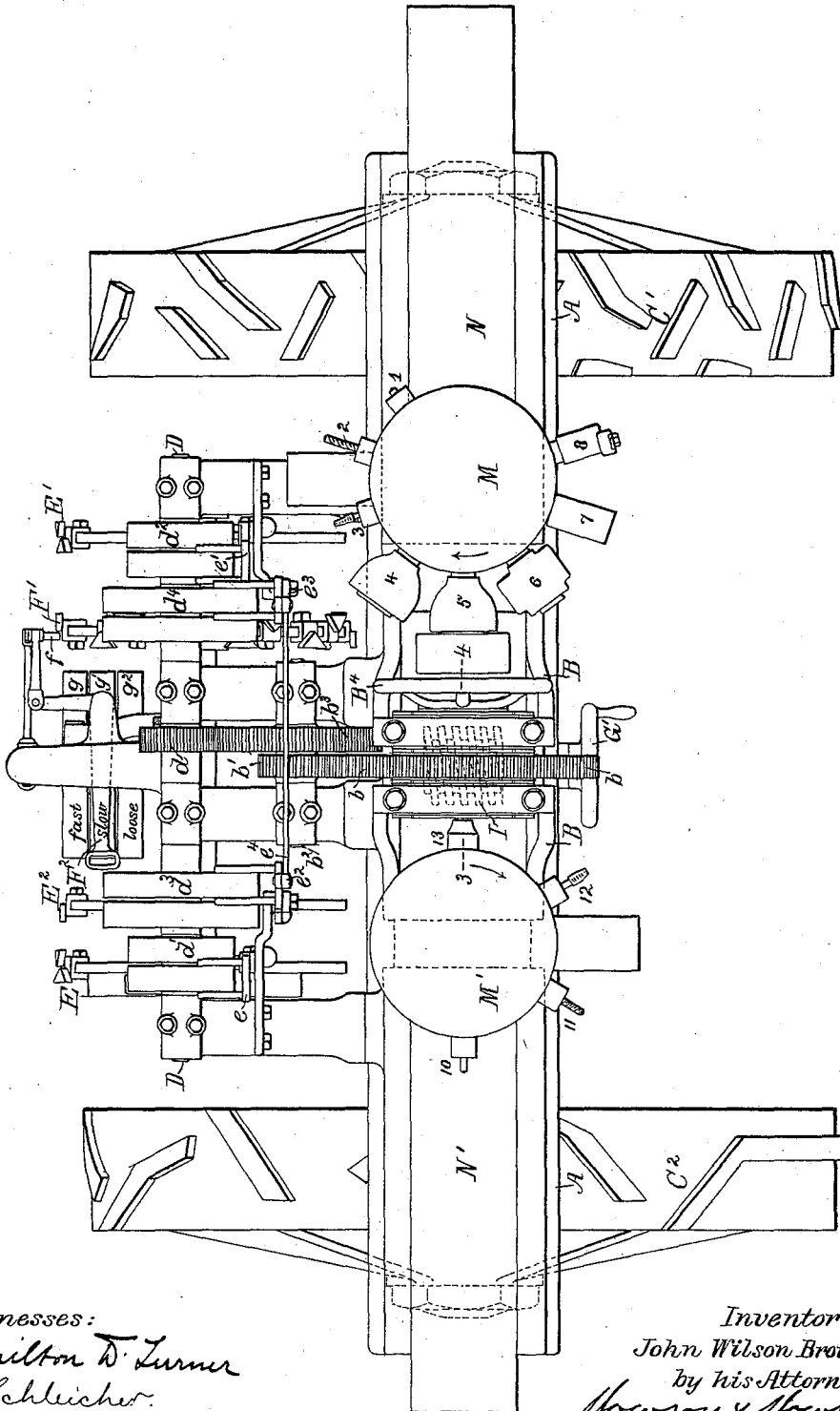

Witnesses:  
Hamilton D. Turner  
R. Schlicher.

Inventor:  
John Wilson Brown, Jr.  
by his Attorneys  
Howson & Howson

No. 610,319.

Patented Sept. 6, 1898.

J. W. BROWN, JR.  
DOUBLE TURRET LATHE.

(Application filed June 23, 1893.)

(No Model.)

4 Sheets—Sheet 2.

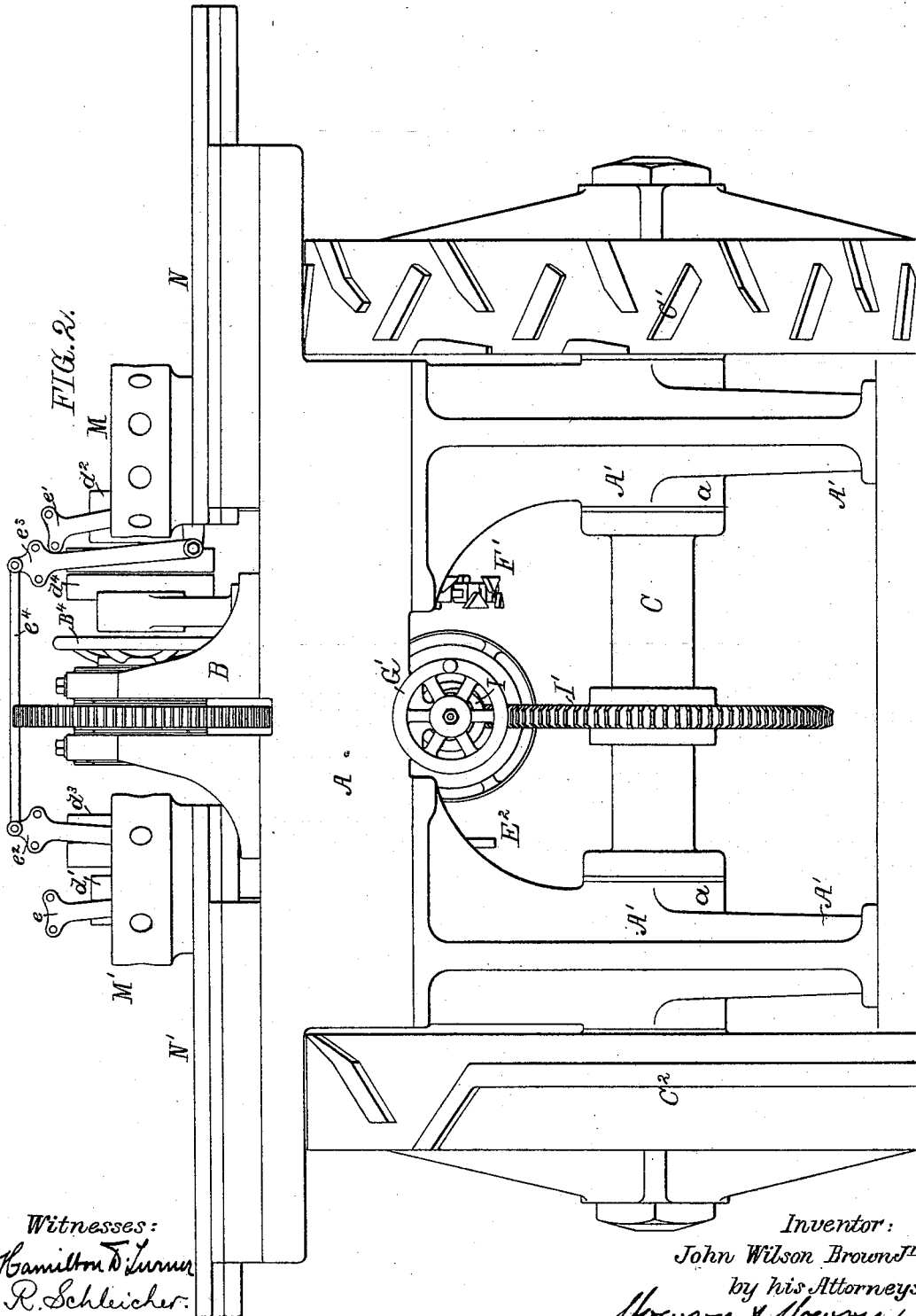

No. 610,319.

Patented Sept. 6, 1898.

J. W. BROWN, JR.  
DOUBLE TURRET LATHE.

(Application filed June 23, 1893.)

(No Model.)

4 Sheets—Sheet 3.

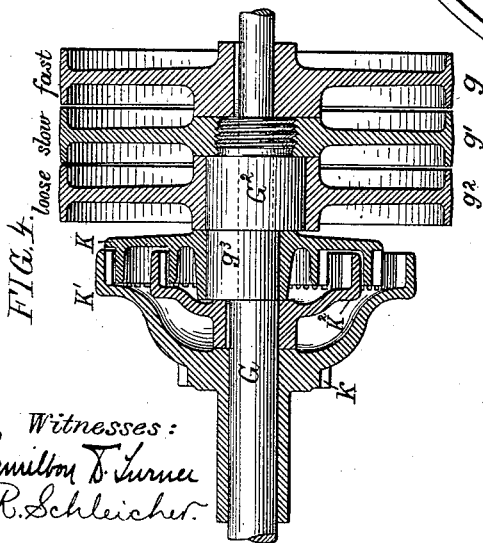
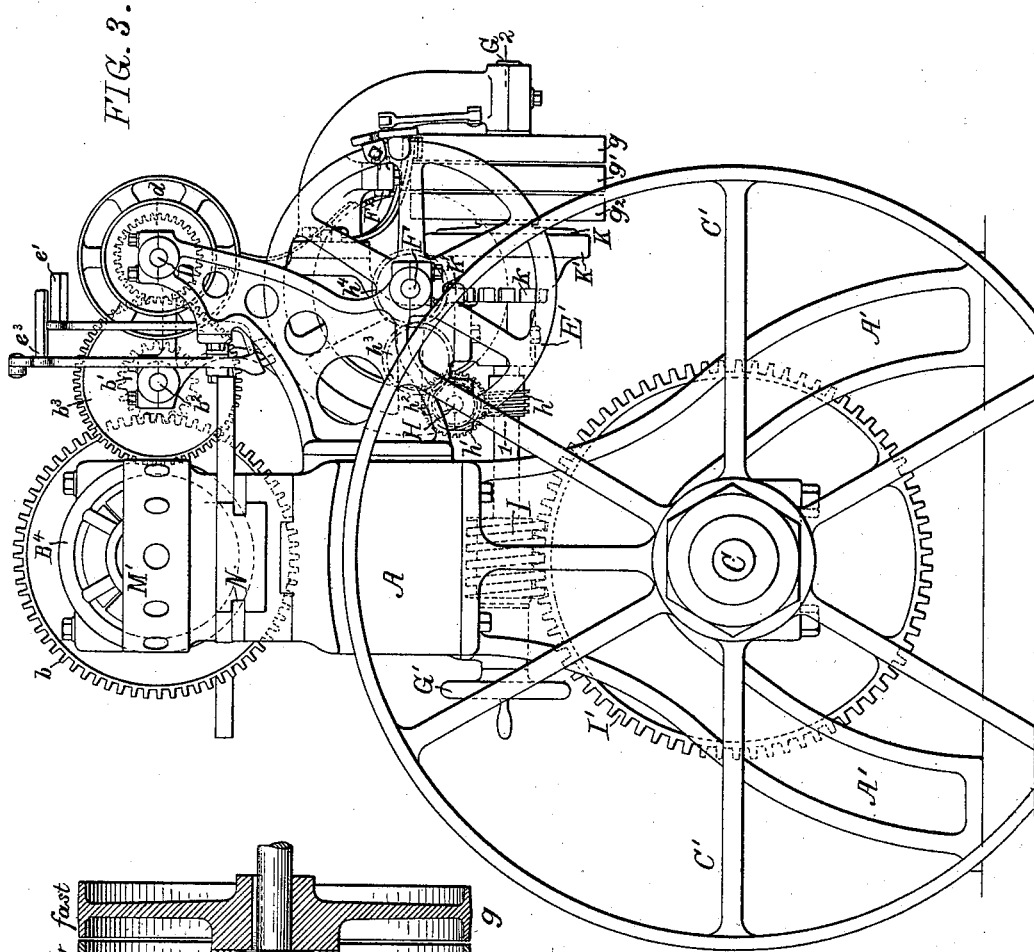

FIG. 4. loose slow fast

Witnesses:  
Hamilton T. Turner  
R. Schleicher.

Inventor:  
John Wilson Brown Jr.  
by his Attorney  
Howson & Howson



# UNITED STATES PATENT OFFICE.

JOHN WILSON BROWN, JR., OF PHILADELPHIA, PENNSYLVANIA.

## DOUBLE-TURRET LATHE.

SPECIFICATION forming part of Letters Patent No. 610,319, dated September 6, 1898.

Application filed June 23, 1893. Serial No. 478,590. (No model.)

*To all whom it may concern:*

Be it known that I, JOHN WILSON BROWN, Jr., a citizen of the United States, residing in Philadelphia, Pennsylvania, have invented a certain Improved Double-Turret Lathe, of which the following is a specification.

The object of my invention is to so construct a turret-lathe that articles can be chucked therein and turned, drilled, or tapped at both ends, as fully described hereinafter.

In the accompanying drawings, Figure 1 is a plan view of my improved turret-lathe. Fig. 2 is a side view. Fig. 3 is an end view. Fig. 4 is a sectional view on the line 1 2, Fig. 3. Fig. 5 is a sectional view on the line 3 4, Fig. 1, of the chuck. Fig. 6 is a section on the line 5 6, Fig. 5; and Fig. 7 is a view illustrating one of the articles or pieces that may be turned, drilled, and tapped upon the machine.

The machine consists, essentially, of a centrally-located chuck in which the article to be turned is clamped, and on each side of this chuck is a turret-head, each head having a number of tools, and the heads are so timed in the present instance that the tools will first turn, then drill, and tap the piece clamped within the chuck.

The article, Fig. 7, that I have shown is a feed-screw for feeding material through a cylinder. This screw has to be drilled and tapped at one end and turned down, drilled, tapped, and grooved and a ring forced in the groove and the ring faced at the opposite end. The machine which I will now proceed to describe automatically performs the several operations while the article is held in the machine by the chuck.

A is the bed of the machine, mounted on suitable legs A', in which are the bearings *a* for the cam-shaft C, having the two turret-head cam-wheels C' C'.

Mounted on the bed A is the chuck-head B. (Clearly shown in Fig. 5.) The housings B' of this chuck-head are secured to the bed by bolts or other means of fastening. The chuck B<sup>2</sup> revolves in the housings, having a gear-wheel *b*, which meshes with a pinion *b'* on the intermediate shaft *b*<sup>2</sup>. On this shaft is a gear-wheel *b*<sup>3</sup>, meshing with a pinion *d* on the shaft D. Within the chuck B<sup>2</sup> is the clamping-ring B<sup>3</sup>, split at *c* and having a series of lon-

gitudinal grooves *c'* in its periphery. This ring is tapered both internally and externally, fitting the tapered chuck B<sup>2</sup> and having at one end a screw-thread, to which is adapted a screw-thread on the hand-nut B<sup>4</sup>, which is turned by the operator when clamping the piece in the chuck. The interior portion of the ring is tapered in the present instance, so as to grip the tapered screw shown in Fig. 7, and on this ring is a lug which engages with the screw, so that it must necessarily turn with the chuck. It will be understood that the ring B<sup>3</sup> can be shaped differently without departing from my invention, so as to accommodate different articles.

The bearing-blocks *c*<sup>2</sup>, *c*<sup>3</sup>, and *c*<sup>4</sup> can be adjusted by wedges *c*<sup>5</sup>, adjusting-screws *c*<sup>6</sup> bearing against the heads of the wedges. By turning these screws the bearing-blocks can be set as desired.

On the shaft D are four sets of pulleys. One pulley of each set is fast on the shaft and the other pulleys loosely mounted thereon. Two of these sets have the pulleys *d*<sup>3</sup> and *d*<sup>4</sup> which act in unison and are simply made in the manner shown in order that narrow belts may be used, so as to shift quickly from the fast to the loose pulleys, which would be impossible if a wide belt was used on wide pulleys. These pulleys are the slow-feed pulleys for the forward rotation of the chuck. The pulley *d*<sup>1</sup> is the pulley for rotating the chuck forward at a higher speed, and the pulley *d*<sup>2</sup> on the opposite end of the shaft D is for driving the chuck in the reverse direction.

The belt-shifters *e*, *e'*, *e*<sup>2</sup>, and *e*<sup>3</sup> for the several pulleys are controlled by shifter-lugs on the wheels E E' E<sup>2</sup>, mounted on the shaft F, which is driven at a slow speed, as described hereinafter. The shifters *e*<sup>2</sup> *e*<sup>3</sup> are connected together by a rod *e*<sup>4</sup>, so that they move together, and are both under the control of the shifter-wheel E<sup>2</sup>, Fig. 1. The lugs on the several wheels E' E<sup>2</sup> are adjustable, so that the movements of the several parts can be timed.

On the shaft F is a shifter-wheel F', having a series of lugs acting upon a pin *f*, secured to an arm which is connected to a belt-shifter F<sup>2</sup>, which shifts the belt upon the fast, slow, and loose pulleys *g* *g'* *g*<sup>2</sup> on the shaft G, extending from front to back of the machine.

This shaft drives the shaft F as well as the shaft C, and these shafts F and C turn at the same speed.

On the shaft G is a worm  $h$ , meshing with the worm-wheel  $h'$  on a shaft H, on which is also a gear-wheel  $h^2$ , meshing with an intermediate gear  $h^3$ , which in turn meshes with a gear-wheel  $h^4$  on the shaft F. Thus motion is imparted to the shaft F from the shaft G through this train of gears. On the shaft G is a worm I, which meshes with a worm-wheel I' on the shaft C. Thus the shaft C is slowly rotated by the shaft G. The shaft G has a hand-wheel G', by which it may be turned by the operator.

The mechanism for driving the shaft G at a slow speed is clearly illustrated in Fig. 4. The high-speed pulley  $g$  is keyed to the shaft G, while the slow-speed pulley  $g'$  is screwed tightly upon a sleeve G<sup>2</sup>, which is loose upon the shaft. This sleeve has an eccentric portion  $g^3$ , upon which is mounted a two-faced gear-wheel K, which meshes with an outer gear-wheel K' and an inner gear K<sup>2</sup>. Both these gears K' and K<sup>2</sup> have internal teeth in the present instance, as clearly shown in Fig. 4. The wheel K<sup>2</sup> is keyed to the shaft, while the wheel K' is loose upon the shaft. On the hub of the wheel K' are ratchet-teeth  $k$ , with which engages a pawl  $k'$ , pivoted to the frame of the machine, so that when the mechanism is driven by the fast pulley the wheel K' is free to revolve with the shaft, not being locked by the pawl; but when the mechanism is moved by the slow pulley the pawl will engage with the teeth, preventing the wheel K' from revolving, as the tendency of the wheel is to revolve in the reverse direction, owing to the peculiar gearing, thus giving differential speed to the parts.

M M' are the turret-heads, mounted upon the slides N N', adapted to ways on the frame A. The slides N N' are controlled by the cams on the cam-wheels C' C<sup>2</sup>. These cams are arranged upon the wheels, according to the number of tools used upon the heads and the character of the work.

In Fig. 2 I have omitted the tools from the drawings; but in Fig. 1 I have shown a series of tools in each head for turning, drilling, and tapping the feed-screw shown in Fig. 7.

Upon the turret-head M is a centering and facing tool 1, the drill 2 for drilling a hole  $x$ , and the tap 3 for tapping a thread in said hole. 4 is an outside cutter for turning down the stem  $x'$ . 5 is a second cutter for the same purpose. 6 is a taper-cutter for turning a taper upon the stem  $x'$  and cutting an annular groove  $x^2$  around the stem in the base of the screw, and 7 is the ring-carrier, in which

is mounted the soft-metal ring. This carrier forces the ring into the groove  $x^2$  of the screw. (See Fig. 7.) 8 is a cutter for trimming the face  $x^3$  of the ring.

On the turret-head M' is a centering and facing tool 10, a drill 11 for drilling the hole  $x^4$  in the opposite end of the screw, Fig. 7, following which is the tap 12 for tapping said hole, and 13 is a thrust-receiver which resists the thrust against the end of the screw while a number of the tools on the head M are acting, so as to relieve the chuck as much as possible. When the tools have finished their work, the heads are moved back, and the piece is removed from the control of the chuck by turning the hand-wheel B<sup>4</sup>.

It will be understood that while I have described my invention in connection with the article shown in Fig. 7 the tool can be used in any instance where a piece has to be either turned, drilled, or tapped at both ends. The chuck can be modified to accommodate the piece, and the tools can also be modified as required.

I claim as my invention—

1. The combination in a turret-lathe, of the central work-chuck open at each end, means for revolving said chuck, a slide on each side of the chuck, a turret-head on each slide carrying tools, means for turning the turret-heads and means for moving the carriages in unison toward and from the work, substantially as described.

2. The combination of the turret-heads, the slides therefor, mechanism for operating said slides and turret-heads, a center chuck mounted between the heads, a driving-shaft geared to said chuck, belt-shifters, a shaft carrying shifting-wheels, operating upon the belt-shifters, a transverse shaft geared to said shifter-shaft and to the cam-shaft controlling the turrets, the whole combined substantially as described.

3. The combination of the central chuck, turrets on each side of said chuck, slides for said turrets, a cam-shaft, cam-wheels thereon controlling the slides, a worm-wheel on said shaft, a transverse driving-shaft, a worm thereon meshing with the worm-wheel, fast and loose pulleys and differential gearing through which a slow motion can be imparted to the shaft, substantially as described.

In testimony whereof I have signed my name to this specification in the presence of two subscribing witnesses.

JOHN WILSON BROWN, JR.

Witnesses:

HENRY HOWSON,  
WILLIAM A. BARR.